

INVERTITORE AUTOMATICO AD INVERSIONE MECCANICA
 AUTOMATIC REVERSING VALVES, MECHANICAL CONTROL

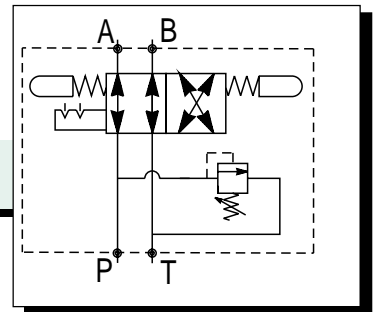

Tipo SD4-IAM SD11-IAM



MATERIALI
 CORPO: Ghisa (210Bar)
 PART. INTERNI: Acciaio Cmt-Tmp-Rett

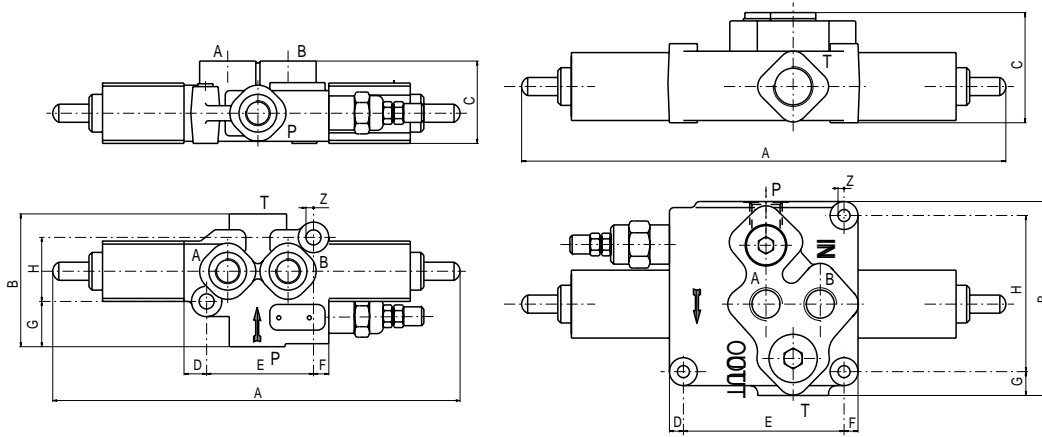

SD 4/IAM

SD 11/IAM

Tipo	P/T	A/B	A	B	C	D	E	F	G	H	Z	Q(L/1')	molle(Bar)
SD4 /IAM	G 3/8	G 3/8	266	90	54	15	70	11	30	46	8,5	35	0-40 20-80 50-200
SD11/IAM	G 1/2	G 1/2	326	125,5	67	11	103	11	15,5	100	8,5	65	



INVERTITORE AUTOMATICO AD AUMENTO DI PRESSIONE
 BASE" NG6 - NG10"
 AUTOMATIC REVERSING VALVES, PRESSURE INCREASE CONTROL

Tipo VIA/AP/6-38 VIA/AP/10-12

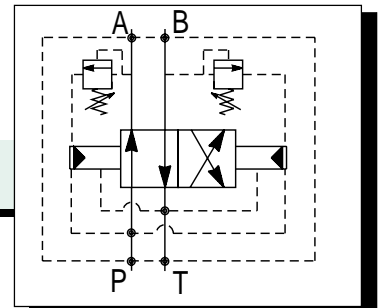

MATERIALI
 CORPO: Ghisa(210Bar)
 PART. INTERNI: Acciaio Cmt-Tmp-Rett

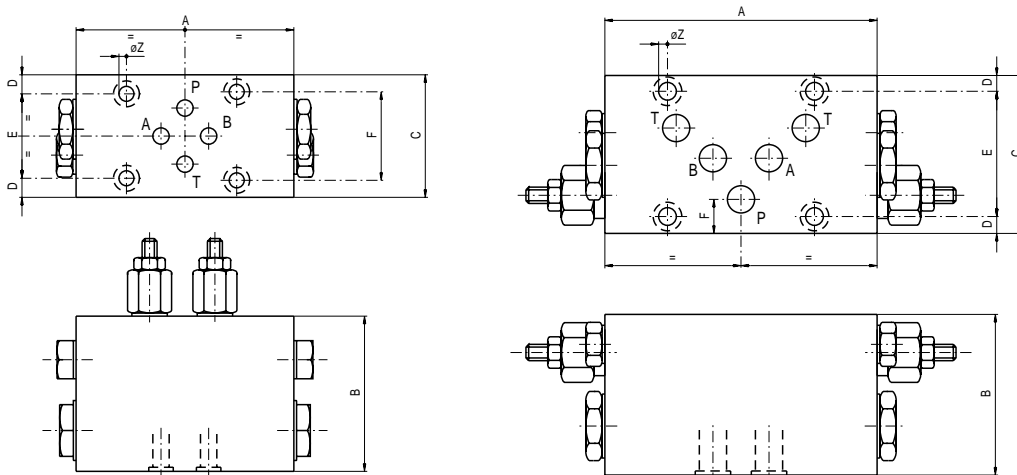

VIA/AP/6-38

VIA/AP/10-12

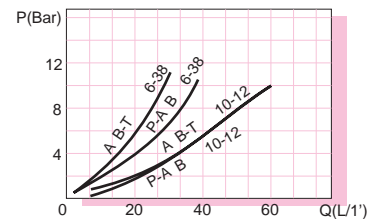

Tipo	A	B	C	D	E	F	Z	Q(L/1')	Qmin(L/1')	molle(Bar)
VIA/AP/6-38	80	57	45	7	31	32,5	5,5	30	4	0-100 50-200
VIA/AP/10-12	100	59	58	6	46	12,3	6,5	60	4	

VALVOLE ANTIURTO E ANTICAVITAZIONE FLANGIATE SU MOTORI CROSS LINE RELIEF VALVES FOR MOTORS

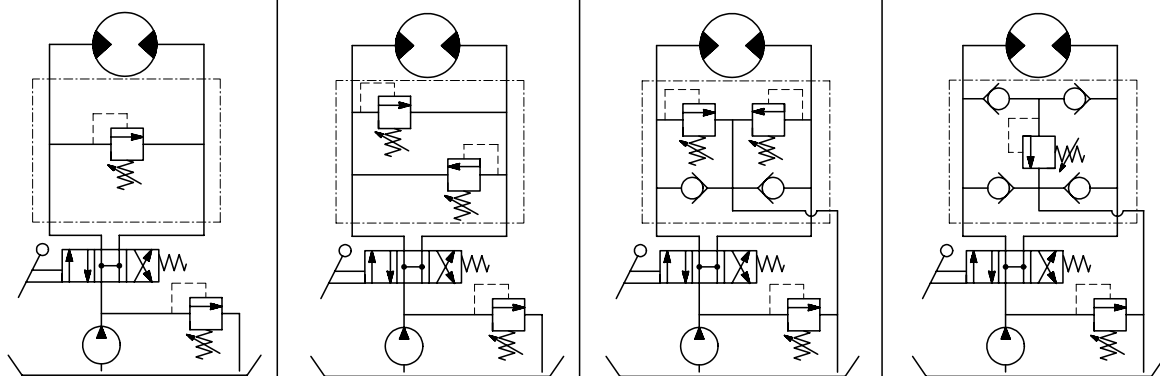

MOTORI / MOTORS		VAIF/S	VADDF/S	VAIF/D	VADDF/D	VAIF/VA	VAA/RU/DF
CASAPPA	RBM	●		●			
	RBP-RBR	●		●			●
	RBS	●	●	●	●	●	●
DANFOSS	OMM	●		●			●
	OMP-OMR	●		●			●
	OMS	●	●	●	●	●	●
	OMT			●	●		●
	OMV				●		●
OILDRIVE		●		●			●
CHAR-LYNN	2000			●		●	
	S			●			
SAMHYDRAULIK.						●	●

VALVOLE REGOLATRICI DI FLUSSO PER MOTORI FLOW REGULATORS VALVES FOR MOTORS

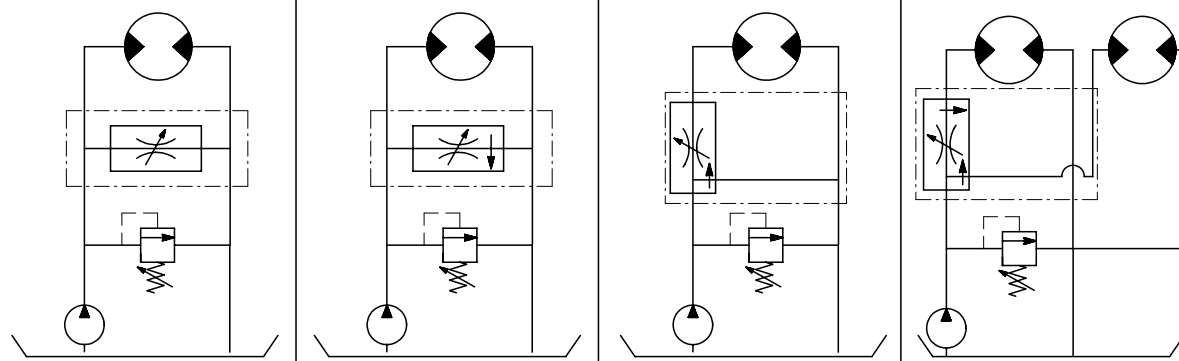

MOTORI / MOTORS		VSRB	VPR/2/SLS	VPR/3/ET	VPR/3/EP
CASAPPA	RBP-RBR	●	●	●	●
	RBS				
DANFOSS	OMM				
	OMP-OMR	●	●	●	●
	OMS				
	OMT				
	OMV				
OILDRIVE			●		
CHAR-LYNN	2000				
	S	●			
SAMHYDRAULIK.		●		●	

VALVOLE DI CONTROLLO MOVIMENTO PER MOTORI CON FRENO
OVERCENTER VALVES FOR MOTORS

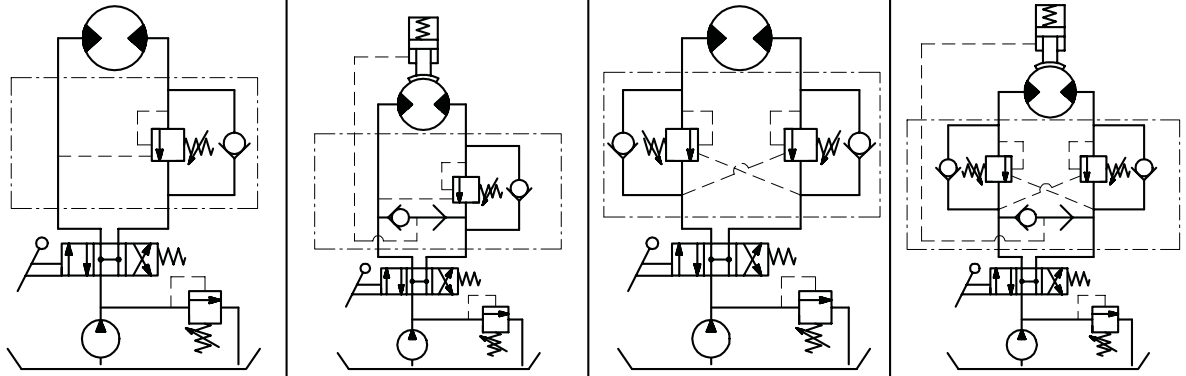

MOTORI / MOTORS		VOSL/SC	VOSL/SC/A	VODL/SC	VODL/SC/A
CASAPPA	RBP-RBR	●	●	●	●
	RBS	●	●	●	●
DANFOSS	OMM				
	OMP-OMR	●	●	●	●
	OMS	●	●	●	●
	OMT	●	●	●	●
	OMV	●	●	●	●
OILDRIVE				●	
CHAR-LYNN	2000	●			
	S		●		
SAMHYDRAULIK.			●	●	●

VALVOLE DI CONTROLLO MOVIMENTO PER MOTORI
MOTION CONTROL AND LOCK VALVES FOR MOTORS

VALVOLE SELETTRICI
SHUTTLE VALVES FOR MOTORS

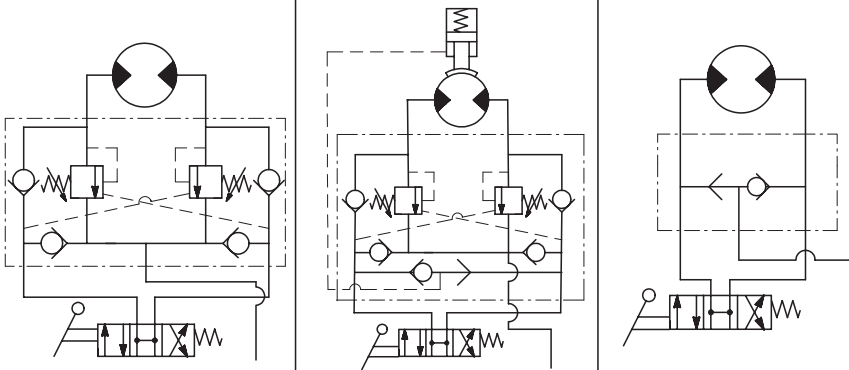

MOTORI / MOTORS		VABAL	VABAL/SF	VT	
CASAPPA	RBP-RBR	●	●	●	
	RBS	●	●	●	
DANFOSS	OMM				
	OMP-OMR	●	●	●	
	OMS	●	●	●	
	OMT	●	●	●	
	OMV	●	●	●	
OILDRIVE			●	●	
CHAR-LYNN	2000	●			
	S			●	
SAMHYDRAULIK.			●		